

Sealoflex Endura

Liquid Applied Waterproofing systems Installation Guide



Based on polymethyl methacrylate (PMMA) technology, Sealoflex Endura combines fast application and curing times with proven waterproofing reliability and superior membrane durability. It is ideal for installations such as public access walkways, external balconies, terraces and podium decks where hard wearing and highly durable surfaces are required.

The Sealoflex Endura System can also be applied as a complete roof overlay system or as a detailing solution in combination with a range of BMI membranes.

This installation manual provides all of the information needed to successfully install a Sealoflex Endura System.

Contents

SECTION 1	4	SECTION 3	20
General Surface Preparation	4	Internal and External Corners	20
Substrate Preparation	4	Upstands	23
Dew Point Calculations	6	Pipe Penetrations	24
Tools and Equipment	7	Internal Rainwater Outlets	26
Adhesion Testing	8	Roof Lights	28
Maintenance	8	Cover Flashings	30
		Field Area	30
SECTION 2	10		
Working with PMMA Technology	10		
System Components - Waterproofing Layer	12		
Substrate Treatment and Primer Guide	13		
Primers	13		
Waterproofing Layer	15		
Surface Finishes	16		
System Components - Balcony and Roof Terrace Waterproofing	17		
General Notes	19		



Our innovative Sealoflex systems provide practical, efficient and, above all, best value waterproofing solutions.



Dallas Harris, BMI Group

Section 1

GENERAL SURFACE PREPARATION

It is the installer's responsibility to prepare the surface so that it meets the required standard prior to applying the Sealoflex Endura System. To meet this standard, each of the conditions listed below should be addressed. (As a minimum, the surface should be clean, dry and sound).

- The existing roof membrane must be thoroughly cleaned. All dust, chalking, bitumen exudate, greases or oils and other loose debris should be removed by mechanical abrasion, power washing or sweeping. Be careful when power washing to preserve the integrity of the existing roof membrane and to avoid damage to the membrane seams (especially adhered seams). Use approved detergents for more effective washing and to remove oil and grease. Organic growth can be treated using an approved fungicidal wash. Allow the roof to dry completely.
- All preliminary work including the formation of upstands, kerbs, box gutters, sumps, grooves, chases, expansion joints etc. and any repairs to the existing surface or flashings, should be completed.
- Roof fixtures and other items such as lightning protection systems, cables, pipes and so on, should be temporarily diverted or completely removed so that the whole surface can receive the liquid applied waterproofing. Redundant or obsolete plant and equipment should be removed and disposed of accordingly. These areas should be repaired where necessary. All plant and equipment should be reinstalled on appropriate supports and bearing pads. (Before replacing any of these fixtures or items, ensure that the Sealoflex Endura System has had adequate time to cure).

- In areas where existing insulation is found to be soft or damaged, cut out the affected area of insulation, replace with a suitable alternative and apply a replacement patch of membrane where necessary. While some areas of wet insulation might be noticeable simply by walking on them, an infrared moisture scan is recommended for all refurbishment projects to accurately determine the moisture content of the surface and where areas of wet insulation exist.
- Where there is evidence of 'standing or ponding water' on the surface, it is strongly advised to introduce positive falls that encourage the movement of rainwater to the designated discharge points.
- In some instances it may be necessary to isolate ventilation or air intake systems.

SUBSTRATE PREPARATION

It is the installer's responsibility to prepare each substrate in accordance with the instructions below. Refer to the Sealoflex Endura Substrate Treatment and Primer Guide to select the appropriate primer for each substrate.

Plywood / OSB

Only Plywood and Oriented Strand Board (OSB) suitable for roof decking should be used. Boards for roof decking should be a minimum of 18 mm thick for joist spans of up to 600 mm.

During installation there should be an appropriate gap between boards to allow for expansion and contraction at the join. Board joints must be reinforced with Sealoflex Endura Reinforcing fabric prior to installing the full System. All boards must be securely fixed and supported in accordance with the board manufacturer's instructions. Any damaged or wet boards should be replaced.

Concrete (and Screeds)

New concrete surfaces must be allowed to cure and harden for a minimum of 28 days.

Mechanical preparation such as milling, grinding with a diamond disc or grit blasting may be necessary to provide a sound, smooth surface for adhesion. Any cracks or gaps in the surface should be repaired and all laitance removed.

Moisture content should be checked and the substrate allowed to dry out if necessary.

Bituminous Surfaces

Check surface for defects. Cut out badly cracked and defective areas of felt as required. Blisters should be star cut, dried out and re-sealed. Check the integrity of up-stands and cut back or repair any layers that have de-bonded. Fill any voids greater than 5 mm with a suitable filling compound.

Solar reflective paint or other coatings on the surface should be removed by power washing, wire brushing or grit blasting as appropriate. Excess or loose mineral should be swept up with a stiff bristle broom and removed.

Note: Application of the Sealoflex Endura System onto textured or mineral finished surfaces will increase the recommended minimum consumption of material.

Asphaltic Surfaces

Check surface for defects. Cut out and fill any blisters or defective areas with a suitable filling compound. Slumped or de-bonded asphalt should be cut back. Areas of badly crazed asphalt should be mechanically abraded to remove the majority of surface irregularities and the resulting voids filled.

Solar reflective paint or other coatings on the surface should be removed by power washing, wire brushing or grit blasting as appropriate. Embedded chippings should be removed using a mechanical scabber.

Note: Application of the Sealoflex Endura System onto textured surfaces will increase the recommended minimum consumption of material.

Synthetic Membranes: PVC, TPO and FPO

Any areas where the synthetic membrane has torn, cracked or buckled, or where scrim is exposed must be repaired using similar compatible materials to the current roof.

Any areas that are loose must be made good; mechanical fasteners may need to be replaced.

Metal Roof Panels

Severely damaged or rusted seams or fasteners must be replaced. Roof panels that are corroded to the point where they have holes in them must be replaced. Areas of light rust can be removed by wire brushing or mechanical abrasion; then treated with an appropriate rust inhibitor to prevent further deterioration.

All fasteners must be retightened, secured or replaced as necessary.

Dents in roof panels must be removed where possible. Severely damaged roof panels must be replaced.

Replace or install sheet metal caps over the open ridge vents when they are rusted on the inside or located in a harsh environment.

Other Substrates

For treatment of other substrates, please contact Icopal Technical Services for advice.

DEW POINT CALCULATIONS

For example, an air temperature of +20 °C with 60 % relative humidity impacting on surfaces of +12 °C or cooler, will produce condensation.

AIR TEMPERATURE (°C)	DEW POINT TEMPERATURE (°C) AT A RELATIVE HUMIDITY OF:											
	30 %	40 %	50 %	55 %	60 %	65 %	70 %	75 %	80 %	85 %	90 %	95 %
+30	+10.5	+14.9	+18.4	+20.0	+21.4	+22.7	+23.9	+25.1	+26.2	+27.2	+28.2	+29.1
+28	+8.8	+13.1	+16.6	+18.1	+19.5	+20.8	+22.0	+23.2	+24.2	+25.2	+26.2	+27.1
+26	+7.1	+11.4	+14.8	+16.3	+17.6	+18.9	+20.1	+21.2	+22.3	+23.3	+24.2	+25.1
+24	+5.4	+9.6	+12.9	+14.4	+15.8	+17.0	+18.2	+19.3	+20.3	+21.3	+22.2	+23.1
+22	+3.6	+7.8	+11.1	+12.6	+13.9	+15.1	+16.3	+17.4	+18.4	+19.4	+20.3	+21.2
+20	+1.9	+6.0	+9.3	+10.7	+12.0	+13.2	+14.4	+15.4	+16.4	+17.4	+18.3	+19.2
+18	+0.2	+4.2	+7.4	+8.8	+10.1	+11.3	+12.5	+13.5	+14.5	+15.4	+16.3	+17.2
+16	-1.5	+2.4	+5.6	+7.0	+8.3	+9.4	+10.5	+11.5	+12.6	+13.5	+14.4	+15.2
+14	-3.3	+0.6	+3.8	+5.1	+6.4	+7.5	+8.6	+9.6	+10.6	+11.5	+12.4	+13.2
+12	-5.0	-1.2	+1.9	+3.3	+4.5	+5.6	+6.7	+7.7	+8.7	+9.6	+10.4	+11.2
+10	-6.8	-3.0	+0.1	+1.4	+2.6	+3.7	+4.8	+5.8	+6.7	+7.6	+8.4	+9.2
+8	-8.5	-4.8	-1.8	-0.5	+0.7	+1.8	+2.9	+3.9	+4.8	+5.6	+6.5	+7.3
+6	-10.2	-6.6	-3.6	-2.3	-1.2	-0.1	+1.0	+1.9	+2.8	+3.7	+4.5	+5.3
+4	-12.0	-8.4	-5.5	-4.2	-3.1	-2.0	-1.0	0.0	+0.9	+1.7	+2.5	+3.3
+2	-13.7	-10.2	-7.3	-6.1	-4.9	-3.9	-2.9	-2.0	-1.1	-0.3	+0.5	+1.3
0	-15.5	-12.0	-9.2	-7.9	-6.8	-5.8	-4.8	-3.9	-3.0	-2.2	-1.4	-0.7
-2	-17.3	-13.8	-11.0	-9.8	-8.7	-7.7	-6.7	-5.8	-5.0	-4.2	-3.4	-2.7
-4	-19.0	-15.6	-12.9	-11.7	-10.6	-9.6	-8.7	-7.8	-6.9	-6.1	-5.4	-4.7

TOOLS AND EQUIPMENT

The following is a list of basic tools and equipment used to install a Sealoflex Endura System. Depending on the project and installers' personal preferences, other tools and equipment may also be used[†].

- Short or medium pile rollers. For field area application, large roller frames should be double armed with screw type extension poles. New roller sleeves should be used at the start of each new application.
- Mini rollers are used for detailing areas, such as corners and penetrations.
- Brushes can be used to apply primers and coatings to small areas. They can also be used to embed the reinforcing fabric into the coating at 90° angles, gaps and cracks.
- A good pair of large, sharp scissors will be needed to cut the reinforcing fabric – **do not use a utility knife.**
- Tape measure and marking pen to measure and mark reinforcing fabric.
- Disposable nitrile gloves are essential for handling the materials during applications.
- Hand held paddle or drill with a decorator's whisk is essential for mixing Parts A and B of two component systems.
- Personal Protective Equipment (PPE) such as gloves, goggles, dust masks and so on.*

- A mechanical scabber may be required to remove solar reflective paint, chippings or other surface finishes.
- Moisture meter to measure substrate moisture.
- Grinder with diamond cup discs.
- Vacuum cleaner.
- Leaf blower.
- Sand paper.
- Adhesion tester.
- Surface temperature thermometer.

* Always refer to the Material Safety Data Sheets for further PPE requirements.

[†] BMI does not endorse or recommend any particular brand of tool or equipment.

ADHESION TESTING

Adhesion tests should always be carried out when the contractor is not certain what the substrate material is or when recommended in the Substrate Treatment and Primer Guide found in this manual. The test should be carried out prior to the start of any project work to determine if or what primer is needed to achieve the best adhesion to the given substrate. It is highly recommended that the contractor or specifier run tests on particular unknown surfaces to check for adhesion.

The following items will be needed in order to carry out the test:

- Small quantity of Sealoflex Endura Waterproof Coating
- Clean water and cloth or hand brush.
- 150 x 175 mm sections of Sealoflex Endura Reinforcing Fabric.
- Small quantity of the appropriate Sealoflex Endura Primer (See Substrate Treatment and Primer Guide).
- Paint brush.
- Permanent marker (to mark the tests).

To carry out a test, the instructions below should be followed taking note of the required times:

- Clean an area of the roof approximately 600 x 600 mm using the clean water and/or the hand brush.
- Section the area in two and mark one 'primed' the other 'un-primed'.
- Use the appropriate Sealoflex Endura Primer and apply a thin even covering as stated in the primer application instructions within this manual. Allow to dry.
- Prepare the Sealoflex Endura Waterproof Coating and apply a small even amount of product to both the primed and non-primed areas. Carefully place the 150 x 175 mm reinforcing fabric into the coating leaving a small tail of untreated fabric showing (approximately 25 mm strip to one edge). Apply a further coat of Sealoflex Endura Waterproof Coating to the saturated fabric and leave to cure.

- Allow the samples to cure for 24 hours.
- Once cured, pull up the sample patches. Both samples will pull from the surface. Compare which of the sample is the harder to remove and which of these samples leaves a quantity of product on the substrate (if any).

It is recommended to photograph both samples as they are pulled back and document the findings for record.

MAINTENANCE

BMI recommend that maintenance staff and / or a maintenance contractor inspect the roof periodically or at least twice a year, ideally before and after the winter period. This ensures that dirt and debris is removed before it can cause damage and that signs of any failure can be reported and remedial action taken at an early stage. Maintenance items, including flashings and sealants, are the responsibility of the building owner and are not included within the scope of a BMI Roofing System Warranty.

The inspection should concentrate on high-risk areas such as roof hatches, drains and around all rooftop equipment, as well as general inspection of the entire roof. The inspector should be looking for membrane damage (cuts and tears), oil or refrigerant leaks, chemical spills from roof plant machinery, or water infiltration into the roofing system itself.

Compliance with the maintenance requirements listed below will aid in assuring a durable and watertight roof waterproofing membrane.

Failure to adequately maintain the roof may invalidate any BMI warranty.

ITEM	ACTION
Internally	Check internal surfaces visually for signs of moisture, leakage or condensation (e.g. damp patches, staining, etc).
General	Remove any unnecessary debris from the roof area particularly objects, which could cause damage to the membrane. Do not use the roof as a working platform for adjoining buildings or further works. If access is required adequate protection must be provided so as not to damage the membrane.
Drainage	Keep the roof surface clean at drain areas to avoid clogging. Clear leaves, silt or other debris, which may cause blockage of outlets or otherwise impede drainage. Check that ponding water is drained from the roof within 48 hours following rain.
Petroleum Products	Keep all petroleum products (solvents, greases, paints, oils or any liquids containing petroleum products) off the membrane to avoid degradation.
Animal Fats	Do not exhaust kitchen wastes (vegetable oils) or other animal fats directly onto the roof surface. They could degrade the membrane.
Chemicals	Contact BMI if any chemicals come in contact with the roofing membrane. Some chemicals could degrade the membrane or cause swelling.
Foot Traffic	Walkways must be provided if regular traffic is required or if rooftop equipment has a regular thirty (30) day or less maintenance schedule. Exercise caution when not walking on walkways, especially on white membranes since ice or frost build-up may not be visible. Membranes are slippery when wet.
Roof Alterations	Check with BMI that the proposed alteration will not invalidate the warranty. Work should be carried out by the roofing contractor who carried out the original installation to limit split liability. Do not allow other trades to fix through the waterproofing membrane without proper advice. This is especially important when having aerials, heating and ventilation equipment or telephone cables fitted.
Cleaning	Pressure washers can be used to clean the Sealoflex Endura Liquid Applied Waterproofing Membrane (including anti-skid surface finishes) where the following limits are observed: <ul style="list-style-type: none"> ▪ Pressure to be no greater than 40 bar / 580 psi. ▪ Minimum 20 cm distance between pressure washer nozzle and surface.
Metal Work	Keep roof maintenance items, such as counterflashing, metal curbs and metal ducts sealed watertight at all times.
Leaks	Try to determine if it is a roof membrane leak or a wall, curb, skylight, metal ductwork or plumbing leak. Deterioration or failure of building components that causes a leak is not covered by the warranty. A water leak may be indicated by soft or warped insulation or the presence of water under the membrane. Physical damage to the membrane or flashing is not covered by the warranty. Please notify BMI if the leak is determined to be membrane related. The building owner is liable to the cost of investigation and repair if the problem is found to be outside the scope of the waterproofing warranty.
Temporary Repairs	Damaged areas of membrane should be repaired as follows. Remove any excess debris, including the cutting away of any loose or damaged membrane. Thoroughly clean the affected area. Once prepared, apply a base layer of Sealoflex Endura Coating at the required coverage rate and install a pre-cut section of Sealoflex Endura Reinforcing Fabric. Complete the repair with the application of Sealoflex Endura Coating as the top layer.
Rooftop Maintenance	When it is necessary for workers to be on the roof to service rooftop equipment, e.g. HVAC units, antennas, etc, workers should be cautioned to use walkways where present and to exercise care with their tools and equipment to avoid puncturing the roofing membrane.

Section 2

WORKING WITH PMMA TECHNOLOGY

All of the components in the Sealoflex Endura System are based on PMMA technology with the exception of Sealoflex Endura Metal Primer which is a solvent based product.

The following guidelines apply to handling and mixing all of the PMMA based components in the Sealoflex Endura System:

Conditions of Use

- Always wear a face mask when using Sealoflex Endura System components containing solvents or monomers in enclosed spaces, or when air limit values are exceeded (refer to Section 8 of the Sealoflex Endura Safety Data Sheets).
- Always ensure forced ventilation with a minimum 7-fold air exchange per hour. Inadequate ventilation will cause adverse chemical reactions when working with PMMA products. In such cases, forced ventilation must ensure that the air is changed 7 times per hour during the application and the cure time. If any problems occur as a result of inadequate ventilation, take the following steps: Remove areas that have not cured fully, clean defective spots with Sealoflex Endura Cleaner, allow to evaporate for at least 20 minutes, then abrade the defective spots thoroughly. Repeat the application process.
- Please also ensure compliance with the EC Safety Data Sheets for individual components.
- Sealoflex Endura System components can only be used within the temperature ranges stipulated on the container labels and on the individual Product Data Sheets.
- When applying Sealoflex Endura primers, the substrate moisture must not exceed 6 % by weight. Ensure that structural measures are taken to prevent moisture penetration of the coating from underneath.

- During application, the surface temperature must be at least 3 °C above the dew point temperature (see Dew Point Calculation Table in this Manual). Below that, moisture may form at the surface which can affect adhesion and curing.
- Mineral (concrete) surfaces must be permitted to fully harden for at least 28 days
- The following tensile strengths must be verified on pre-treated test surfaces:
 - Concrete:** in the centre, at least 1.5 N/mm², individual value not less than 1.0 N/mm².
 - Screed:** in the centre, at least 1.0 N/mm², individual value not less than 0.7 N/mm².
 - Asphalt:** in the centre, at least 0.8 N/mm², individual value not less than 0.5 N/mm².
- The suitability of the substrate must always be checked on a case-by-case basis. The substrate must be clean, dry and free of cement bloom, dust, oil, grease and other adhesion-reducing dirt.
- Before commencing any coating work and during the work itself, it is essential to ensure the correct gradient and evenness of the substrate. Any corrections required must be taken into account during this work.
- When carrying out coating work, always ensure compliance with the permissible tolerances for building construction (DIN 18202, Table 3, line 4).
- Do not apply if rain is imminent.

What to do if Work is Interrupted

If work is interrupted for more than 12 hours, or soiled by rain etc., the intersection must be activated with Sealoflex Endura Cleaner and left to evaporate for at least 20 minutes. Dry the substrate, check the areas concerned for any defective spots and if necessary repeat the relevant work step after appropriate pre-treatment.

Consumption Rates and Waiting Times

The specified consumption rates apply only to smooth, even surfaces. Special allowances must be made for unevenness, roughness and porosity. Information regarding airing and waiting times apply to a substrate and ambient temperature of +20 °C.

Mixing instructions

- Stir the base resin thoroughly, then add the appropriate amount of catalyst and continue mixing with a slow-running mixing machine. Mixing time is 2 minutes.
- The required amount of base resin must always be weighed and confirmed before adding the corresponding amount of catalyst.
- The mixing ratio of base resin to catalyst corresponds to the proportion in which they are supplied or is specified on the container label. Please also refer to the information contained in the Product Data Sheets.



SEALOFLEX ENDURA SYSTEM COMPONENTS - WATERPROOFING LAYER

SYSTEM COMPONENT	DESCRIPTION	COMPONENT SIZE	CONSUMPTION
Surface Preparation			
Sealoflex Endura Fill Paste	Used to fill cracks, gaps, etc. up to 3 mm (RAL 7032)	15 kg	1.4 kg/m ² /mm
Substrate Primers			
Sealoflex Endura Asphalt Primer	For use on asphalt and bitumen	10 kg	0.4 kg/m ²
Sealoflex Endura Concrete Primer	For use on concrete and cementitious substrates	10 kg	0.4 kg/m ²
Sealoflex Endura Metal Primer	For use on prepared metals	2.5 litres	0.08 - 0.1 L/m ²
Waterproof Coating			
Sealoflex Endura Waterproof Coating - summer and winter grades	PMMA waterproof coating for flat areas (RAL 7031)	20 kg	3 kg/m ²
Sealoflex Endura Detail Coating - summer and winter grades	PMMA waterproof coating for detailing (RAL 7031)	10 kg	3 kg/m ²
Sealoflex Endura Fibre Fill	PMMA waterproof coating with chopped strand fibres (RAL 7031)	10 kg	3 kg/m ²
Reinforcing Membrane			
Sealoflex Endura Reinforcing Fabric	110 g/m ² polyester reinforcing fleece	1.05 m x 50 m; 0.35 m x 50 m; 0.15 m x 50 m	N/A
Coloured Top Coat			
Sealoflex Endura Finish Coat	Coloured finishing coat (RAL 7030; RAL 7043)	10 kg	0.5 - 0.7 kg/m ²
Accessories			
Sealoflex Endura Cat Powder	Catalyst powder	100 g bags	N/A
Sealoflex Endura Cleaner	Ethyl acetate	9 litres	N/A

SUBSTRATE TREATMENT AND PRIMER GUIDE

SUBSTRATE	PRE-TREATMENT	PRIMER
Asphalt; APP and SBS modified bitumen membranes; hot and cold bitumen coatings	Grinding, milling or dust free shot blasting	Sealoflex Endura Asphalt Primer
Concrete; light weight concrete; plaster or masonry; screeds; tiles; timber	Grinding, milling or dust free shot blasting	Sealoflex Endura Concrete Primer
Metals – aluminium; copper; stainless steel; galvanised steel; zinc	Abrade; wipe with Sealoflex Endura Cleaner	Sealoflex Endura Metal Primer*
Epoxy resin coating	Abrade; adhesion and compatibility test	No primer
uPVC Sky light frames	Wipe with Sealoflex Endura Cleaner	No primer
Plastic sheeting (PVC, EVA)	Wipe with Sealoflex Endura Cleaner	No primer
PU coating	Abrade; adhesion and compatibility test	No primer
Rigid PVC	Wipe with Sealoflex Endura Cleaner	No primer

*As an alternative to using Sealoflex Endura Metal primer, surfaces may be prepared by wiping with Sealoflex Endura Cleaner and roughening by mechanical abrasion. All loose rust must be removed first.

PRIMERS

Sealoflex Endura Asphalt Primer

Surfaces to be primed: Asphalt and bitumen.

Application Conditions

Sealoflex Endura Asphalt Primer can be applied at substrate and ambient temperatures between 0 °C and +35 °C; and relative humidity of up to 95%.

Before applying Sealoflex Endura Asphalt Primer:

- Make sure the surface has been properly prepared.
- Ensure all tools and equipment are available and ready to use.

Mixing Instructions

After thoroughly mixing the base resin, the corresponding catalyst quantity is added to and mixed with a slow-running mixing machine until there are no more lumps. Stirring time at least 2 min. Transfer to another receptacle and mix again.

Mixing Ratio

Temperature range of:

- 0 °C to +5 °C 10 kg base resin + 0.6 kg catalyst (6%)
- +5 °C to +15 °C 10 kg base resin + 0.4 kg catalyst (4%)
- +15 °C to +35 °C 10 kg base resin + 0.2 kg catalyst (2%)

Application

- Apply primer to surface with a universal roller to form a film layer. Then cross-coat evenly.
- The minimum consumption is 0.4 kg/m² depending on the texture of the surface.

Pot Life: 15 minutes.

Rainproof: 25 minutes.

Can be recoated: 45 minutes.

Can be loaded: 2 hours.

Sealoflex Endura Concrete Primer

Surfaces to be primed: Concrete and cementitious substrates.

Application Conditions

Sealoflex Endura Concrete Primer can be applied at substrate and ambient temperatures between 0 °C and +35 °C; and relative humidity up to 95%.

Before applying Sealoflex Endura Concrete Primer:

- Make sure the surface has been properly prepared.
- Ensure all tools and equipment are available and ready to use.

Mixing Instructions

- 1 Measure the appropriate weight of catalyst for the weight of resin and the temperature.
- 2 Add the catalyst to the pre-mixed / decanted resin.
- 3 Thoroughly mix the resin and catalyst using a slow speed mixer for a minimum 2 minutes until the catalyst has been evenly distributed and leave for a minimum of 1 minute to allow the catalyst to fully dissolve.
- 4 Re-mix and use the mixed material within the pot life.

Mixing Ratio

Temperature range of:

- 0 °C to +5 °C 10 kg base resin + 0.6 kg catalyst (6%)
- +5 °C to +15 °C 10 kg base resin + 0.4 kg catalyst (4%)
- +15 °C to +35 °C 10 kg base resin + 0.2 kg catalyst (2%)

Application

- 1 Apply primer to surface with a universal roller to form a film layer. Then cross-coat evenly.
- 2 The minimum consumption is 0.4 kg/m² depending on the texture of the surface.

Pot Life: 15 minutes.

Rainproof: 25 minutes.

Can be recoated: 45 minutes.

Can be loaded: 2 hours.

Sealoflex Endura Metal Primer

Surfaces to be primed: Prepared metal.

Application Conditions

Sealoflex Endura Metal Primer can be applied at substrate and ambient temperatures between 0 °C and +35 °C; and relative humidity up to 85%.

Before applying Sealoflex Endura Metal Primer:

- Make sure the surface has been properly prepared.
- Ensure all tools and equipment are available and ready to use.

Mixing Instructions

Thoroughly mix the primer in the drum with a paint stirrer until a smooth, uniform consistency is achieved.

Application

Apply using a short pile (mohair) roller or brush.

Consumption Rate

0.08 – 0.10 L/m² based on smooth, even, non absorbant substrate.

Can be recoated after approximately 30 minutes using the spray can and approximately 60 minutes using roller or brush.

Important Note

The final adhesive strength of the Sealoflex Endura Metal Primer is reached after approximately 3 days. A peel test should not be performed before this time.

Times will be increased at lower temperatures and reduced at higher temperatures.

WATERPROOFING LAYER

The Sealoflex Endura System is applied in a continuous sequence of base coat, fabric reinforcement and top coat. This process is referred to as 'wet on wet'. When the System is cured it becomes a fully saturated, reinforced waterproofing membrane.

When using the System for a complete roof installation, whether for new construction or for refurbishment, it is recommended to waterproof the roof details first, before proceeding to the field area. The use of masking tape to mark off the detailing areas before applying the System, is also recommended.

Lastly, it is recommended to pre-cut the reinforcing fabric to be used on details into the required lengths and shapes, before proceeding with the installation.

Before applying the Sealoflex Endura System:

- Make sure the surface has been properly prepared and primed with the recommended Primer.
- Ensure all tools and equipment are available and ready to use.

Application Conditions

Apply when atmospheric and substrate temperatures are between 0 °C and 35 °C and the surface is 3 °C above the dew point. (See Dew Point Calculation Table in this manual) If the surface is below or at dew point temperature then moisture can form at the surface, which can affect adhesion.

Do not apply if rain is imminent.

Mixing Instructions - Sealoflex Endura Waterproof Coating and Sealoflex Endura Detail Coating

- 1 Measure the appropriate weight of catalyst for the weight of resin and the temperature.
- 2 Add the catalyst to the pre-mixed / decanted resin.
- 3 Thoroughly mix the resin and catalyst using a slow speed mixer for a minimum 2 minutes until the catalyst has been evenly distributed and leave for a minimum of 1 minute to allow the catalyst to fully dissolve.
- 4 Re-mix and use the mixed material within the pot life.

Mixing Ratio

Temperature range of:

- 0 °C to +5 °C 10 kg base resin + 0.6 kg catalyst (6%)
- +5 °C to +15 °C 10 kg base resin + 0.4 kg catalyst (4%)
- +15 °C to +35 °C 10 kg base resin + 0.2 kg catalyst (2%)

Curing Times (at 20 °C)

Pot Life: 15 minutes.

Rainproof: 25 minutes.

Can be walked on / recoated: 45 minutes.

Resistant after: 2 hours.

SURFACE FINISHES

Anti-skid Walkway System

To create a surface above the waterproofing layer that is suitable for foot traffic install the Sealoflex Endura Anti-skid Walkway System. Designed to provide the optimum combination of aesthetic and functional performance the Sealoflex Endura Anti-skid Walkway System forms an integral part of a complete Sealoflex Endura System where waterproofing and surfacing are required.

Install the Sealoflex Endura Anti-skid Walkway System as follows:

- 1 Tape the designated area with good quality masking tape.
- 2 Wipe the area with Sealoflex Endura Cleaner if applying 12 hours after the Sealoflex Endura System has cured and wait 20 minutes.
- 3 Apply a thin coat of Sealoflex Endura Waterproof Coating at a consumption rate of 1.5 L/m².
- 4 Broadcast Sealoflex Endura Anti-skid granules onto the wet layer of coating at a consumption rate of 6 kg/m².
- 5 Allow at least 45 minutes for the coating to cure before sweeping away the excess granules.
- 6 Ensure that no loose granules remain on the surface.
- 7 Apply Sealoflex Endura Finish Coat at a consumption rate of 0.5 kg/m², ensuring an even finish.

Please Note

- The System is ready to receive foot traffic, a minimum of 2 hours after installation.

SEALOFLEX ENDURA SYSTEM COMPONENTS - BALCONY AND ROOF TERRACE WATERPROOFING

SYSTEM COMPONENT	DESCRIPTION	COMPONENT SIZE	CONSUMPTION
Surface Preparation			
Sealoflex Endura Fill Paste	Used to fill cracks, gaps, etc. up to 3 mm (RAL 7032)	15 kg	1.4 kg/m ² /mm
Substrate Primers			
Sealoflex Endura Asphalt Primer	For use on asphalt and bitumen	10 kg	0.4 kg/m ²
Sealoflex Endura Concrete Primer	For use on concrete and cementitious substrates	10 kg	0.4 kg/m ²
Sealoflex Endura Metal Primer	For use on prepared metals	0.5 litres (spray can) and 2.5 litres (drum)	0.08 - 0.1 L/m ²
Waterproof Coating			
Sealoflex Endura Balcony Coating - summer and winter grades	PMMA resin for balcony waterproofing (RAL 7031)	10 kg	3 kg/m ²
Sealoflex Endura Detail Coating	PMMA waterproof coating for detailing (RAL 7031)	10 kg	3 kg/m ²
Sealoflex Endura Fibre Fill	PMMA waterproof coating with chopped strand fibres (RAL 7031)	10 kg	3 kg/m ²
Reinforcing Membrane			
Sealoflex Endura Reinforcing Fabric	110 g/m ² polyester reinforcing fleece	1.05 m x 50 m; 0.35 m x 50 m; 0.15 m x 50 m	N/A
Surface Finish			
Sealoflex Endura BT Resin - summer and winter grades	Levelling resin to receive surfacing layers	10 kg	4 kg/m ²
Sealoflex Endura BT Filler	Filler mixed with levelling resin to receive large quartz	23 kg	4 kg/m ²
Sealoflex Endura Finish Coat	Coloured finishing coat	10 kg	0.5 - 0.7 kg/m ²
Sealoflex Endura Large Quartz	0.7 - 1.2 mm quartz	25 kg	6 kg/m ²
Accessories			
Sealoflex Endura Cat Powder	Catalyst powder	100 g bags	N/A
Sealoflex Endura Cleaner	Ethyl acetate	9 litres	N/A

BALCONY AND ROOF TERRACE WATERPROOFING

The Sealoflex Endura System offers two types of balcony and roof terrace installation depending on the designation of the construction – cantilevered or above occupied (habitable) spaces.

Cantilevered Balconies and Terraces

- Surfaces are prepared and primed using the appropriate Sealoflex Endura Primer.
- Sealoflex Endura Detail Coating + Sealoflex Endura Reinforcing Fabric is applied to all upstands and pipe penetrations at a consumption rate of 3 kg/m².
- Sealoflex Endura BT Resin mixture is applied to the area at a consumption rate of 4 kg/m².
- Sealoflex Endura Large Quartz is broadcast into the wet resin at a consumption rate of 6 kg/m².
- After two hours the excess Quartz is removed.
- Sealoflex Endura Finish Coat is then applied to the area.

Balconies and Terraces above Occupied Spaces

- Surfaces are prepared and primed using the appropriate Sealoflex Endura Primer.
- Sealoflex Endura Balcony Coating and Sealoflex Endura Detail Coating with Sealoflex Endura Reinforcing Fabric are used as the waterproofing layer at a consumption rate of 3 kg/m².
- After a minimum of 45 minutes, Sealoflex Endura BT Resin mixture is applied to the area at a consumption rate of 4 kg/m².
- Sealoflex Endura Large Quartz is broadcast into the wet resin at a consumption rate of 6 kg/m².
- After two hours the excess quartz is removed.
- Sealoflex Finish Coat is then applied to the area.

GENERAL NOTES

Fabric Overlaps

All overlaps of Sealoflex Reinforcing Fabric on field areas and details should be a minimum of 50 mm. Always ensure that there is sufficient coating between fabric overlaps and that no air is trapped within the overlap.

Transitions to other waterproofing membranes e.g. a bitumen membrane when using the Sealoflex Endura System as a detailing solution, must overlap by a minimum of 100 mm.

Waterproofing Height Above Roof Deck

Follow local guidelines on minimum height above roof deck to receive waterproofing membrane. BMI recommends a minimum height of 150 mm above the deck, with at least 10 mm of coating extending above the top edge of the fabric to ensure proper sealing.

Day Joints

Where new waterproofing membrane is to be joined to existing cured membrane at a day joint, the new application should be lapped on to the existing by 50 mm.

Sealoflex Endura Cleaner must be applied to the existing surface and allowed to evaporate for 20 minutes before continuing with the new application.

Cleaning of Tools and Equipment

Tools must be cleaned thoroughly with Sealoflex Endura Cleaner on completion of work or when work is interrupted for extended periods. Wait for approximately 20 minutes for the cleaner to evaporate before using the tool again.

Health & Safety

Safety Data Sheets for all components in the Sealoflex Endura System and any associated products must be available on site. The Authorised Contractor must read and understand them before commencing work.

All relevant Health & Safety signage must be posted in advance of any System application to inform members of the public, road users or other contractors of the works in progress.

Important Note

When transporting, storing and working with Sealoflex Endura System Components, always ensure compliance to all pertinent safety data sheets and technical codes of practice, and pay attention to all markings, hazard information and safety tips on the containers.

Storage

Keep containers firmly sealed.

Containers must be stored in a dry, cool (but frost-free) and well ventilated place.

Protect against heat and direct sunlight.

Storage stability: at least 6 months.

In winter, store containers at room temperature prior to use where possible.

Clean Working Environment

The areas used for mixing and transferring products to other containers must be covered with a suitable plastic sheet (e.g., PE sheet), before work commences. Resin components on the substrate to be coated that have not been cured with hardener will cause adverse chemical reactions.

Disposal of Waste Product and Containers

All waste containers must be disposed of in accordance with the Local Authority and Environmental requirements. See Safety Data Sheets for guidance.

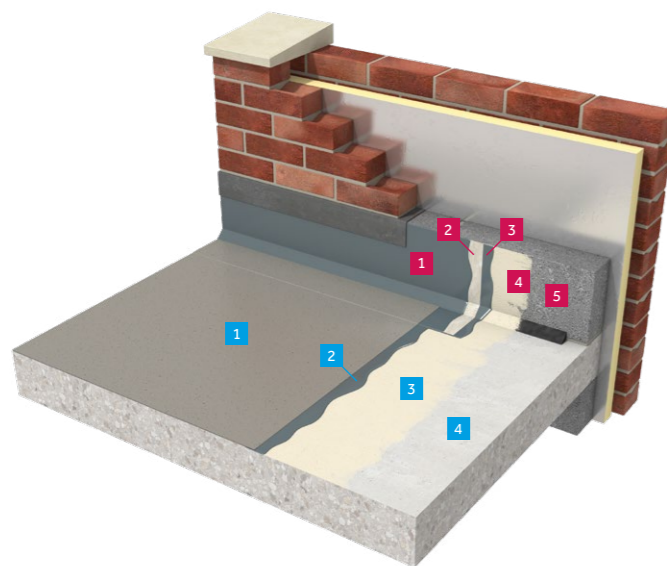

Horizontal Surface

- Sealoflex Endura Surface (Sealoflex Endura Large Quartz + Sealoflex Endura Finish Coat)
- Sealoflex Endura BT Resin
- Sealoflex Endura Concrete Primer
- Concrete Substrate

Vertical Surface

- Sealoflex Endura Detailing Coating (top coat)
- Sealoflex Endura Reinforcing Fabric
- Sealoflex Endura Waterproof Coating (base coat)
- Sealoflex Endura Concrete Primer
- Substrate

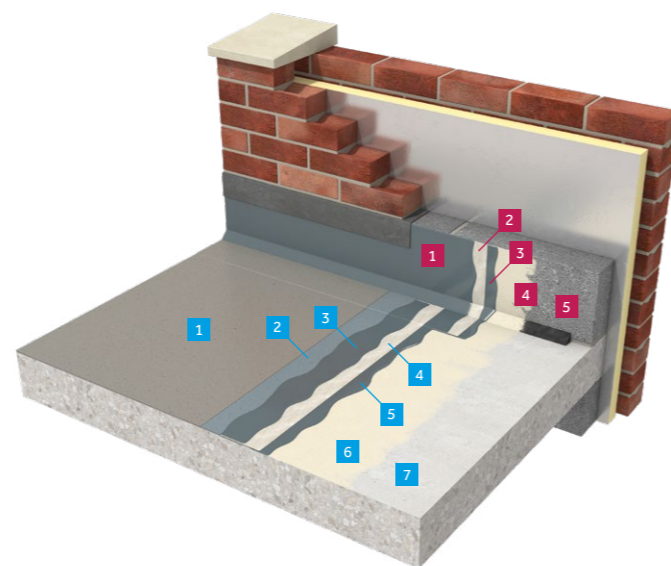

Horizontal Surface

- Sealoflex Endura Finish Coat
- Sealoflex Endura BT Resin + Sealoflex Endura Large Quartz
- Sealoflex Endura Balcony Coating (top coat)
- Sealoflex Endura Reinforcing Fabric
- Sealoflex Endura Balcony Coating (base coat)
- Sealoflex Endura Concrete Primer
- Concrete Substrate

Vertical Surface

- Sealoflex Endura Detail Coating (top coat)
- Sealoflex Endura Reinforcing Fabric
- Sealoflex Endura Detail Coating (base coat)
- Sealoflex Endura Concrete Primer
- Substrate

Section 3

INTERNAL AND EXTERNAL CORNERS

All corner details must be double reinforced with the Sealoflex Endura Reinforcing Fabric.

- 1 Cut circles approximately 100 mm in diameter from the Reinforcing Fabric.
- 2 Fold twice and cut along one fold into the centre.
- 3 Apply a base coat of Sealoflex Endura Waterproof Coating to the area around the corner and place the circle into the base coat as shown.

- 4 Using a roller or a brush embed the fabric into the base coat making sure there are no creases in the fabric and that no air is trapped beneath it.
- 5 For the internal corner, make sure there is a layer of liquid between the folds of the fabric.
- 6 Tape the vertical surface a minimum of 160 mm above the horizontal surface and the horizontal surface a minimum of 120 mm out from the base of the vertical surface on either side of the corner.
- 7 Cut a strip of Reinforcing Fabric so that it extends 50 mm around each corner as shown.

Fabric Cuts for Internal Corner

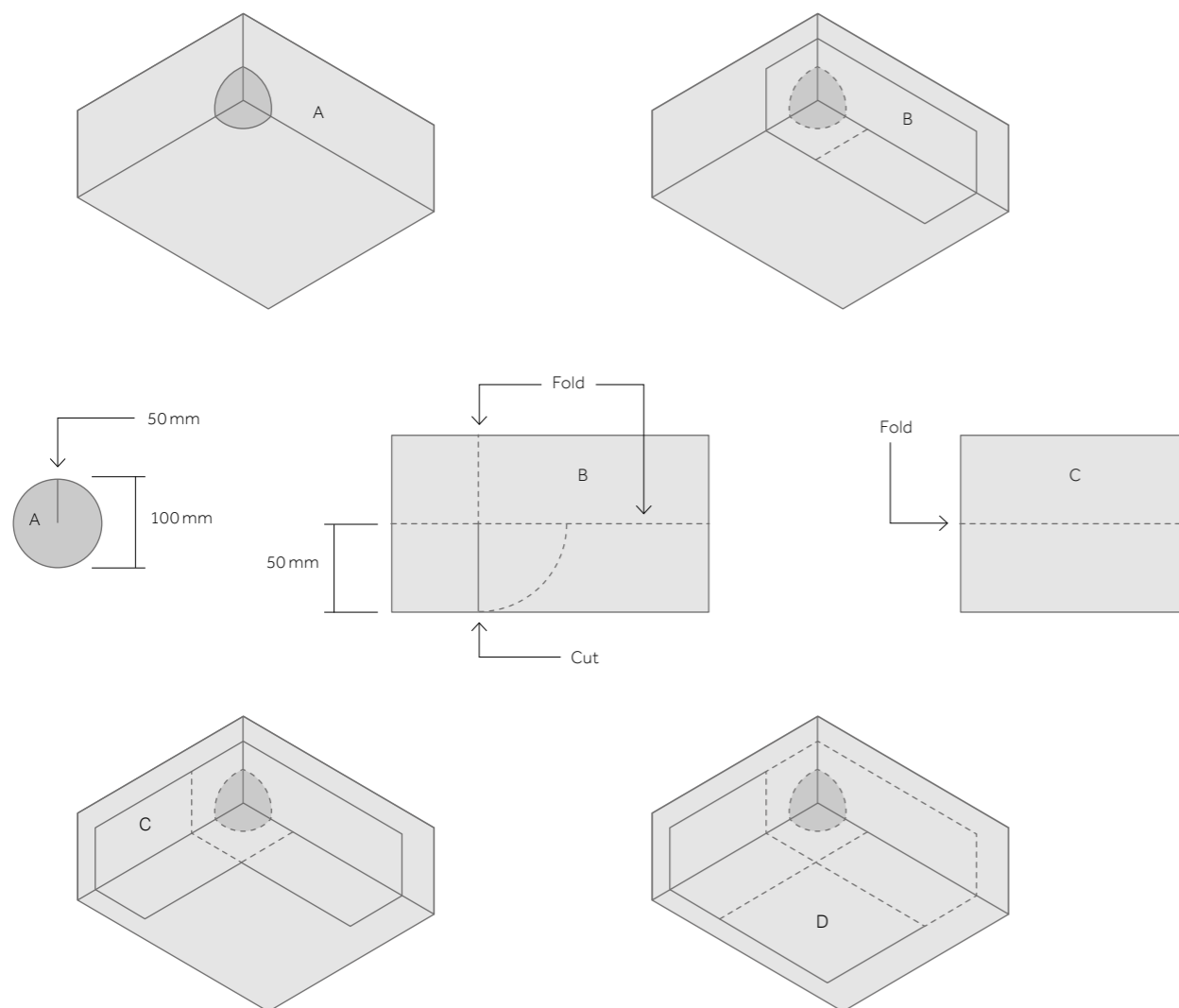

Fabric A



Fabric B



Fabric C

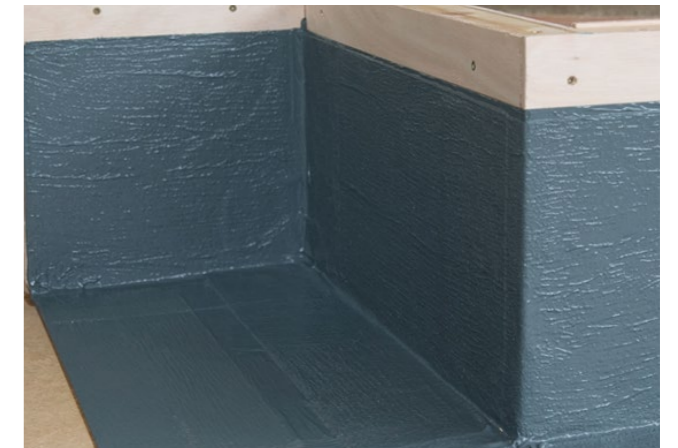

- 8 Apply a base coat of Sealoflex Endura Waterproof Coating to the vertical and horizontal areas around the corner, covering the saturated Reinforcing Fabric already installed.
- 9 Make a cut 100 mm long that is 50 mm from the edge of the fabric as shown.
- 10 Place the Reinforcing Fabric at least 150 mm up from the horizontal surface on the vertical, press into the angle at the base and 'return' the fabric around the corner as shown.

- 11 Using a roller or a brush embed the fabric into the base coat making sure there are no creases in the fabric and that no air is trapped beneath it.
- 12 For the internal corner, make sure there is a layer of liquid between the folds of the fabric.
- 13 Apply the top coat of Sealoflex Endura Waterproofing Coating to the saturated Reinforcing Fabric.
- 14 Remove the tape before the System cures.



Fabric A

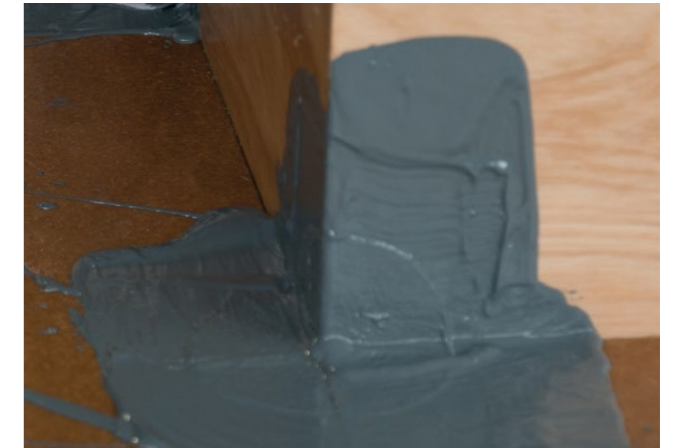

Fabric B

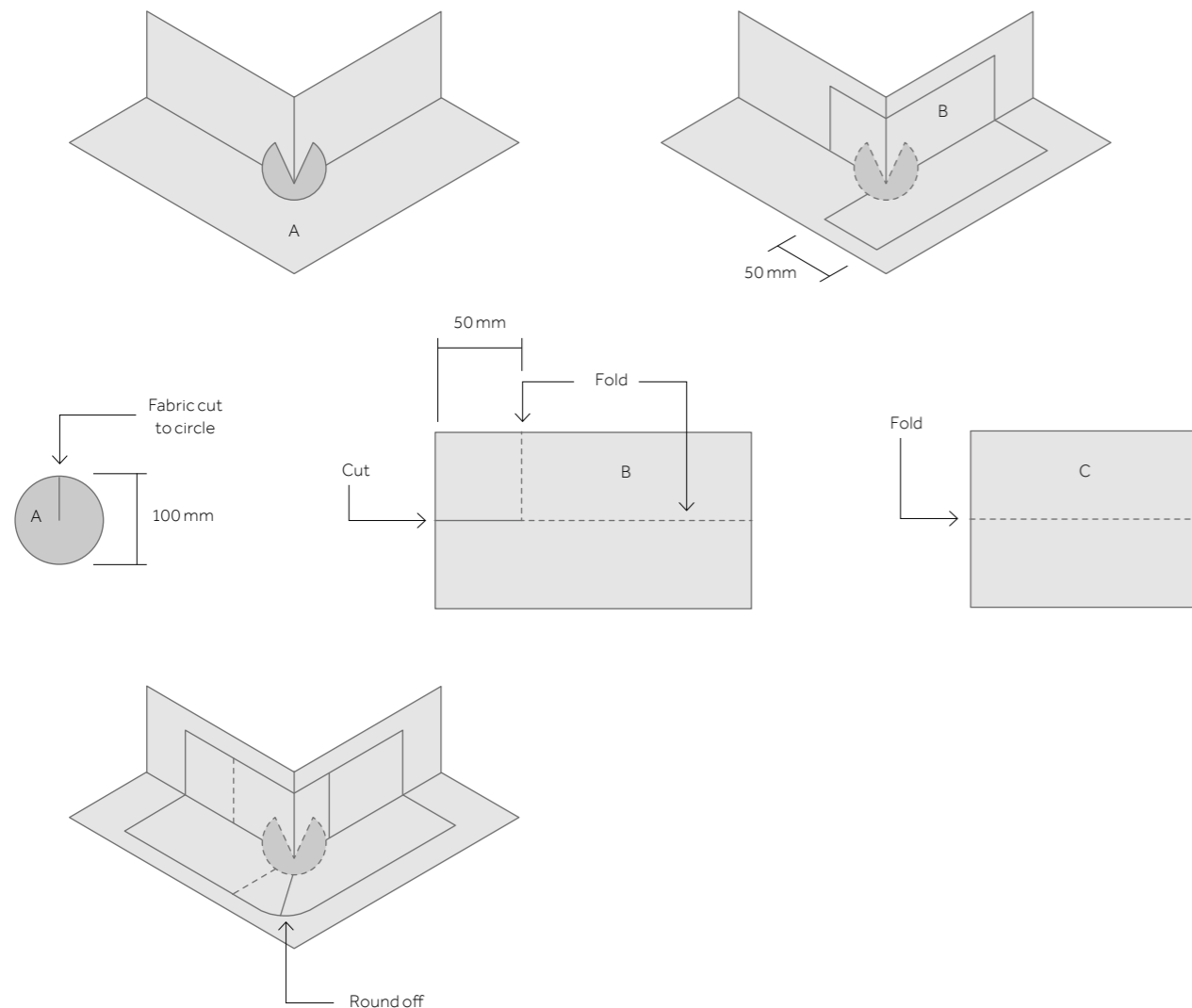
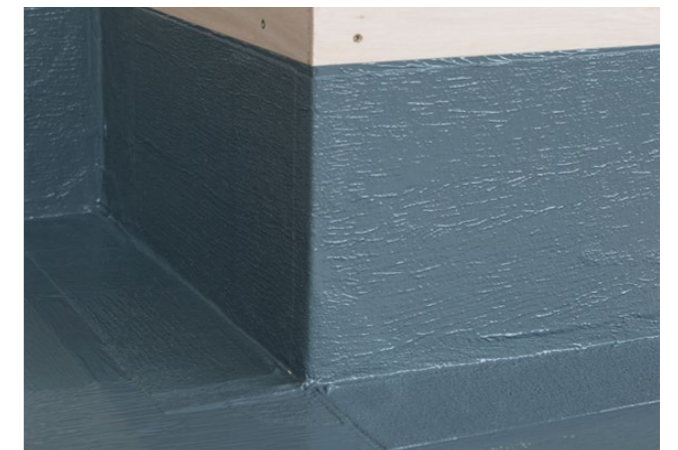

UPSTANDS

All junctions at vertical and horizontal surfaces must be reinforced with Sealoflex Endura Reinforcing Fabric. Although it is possible to apply Reinforcing Fabric direct from the roll, in certain conditions such as where surfaces are uneven or in windy weather, it is advisable to cut the fabric into more manageable lengths.

- 1 Tape the vertical surface a minimum of 160 mm above the horizontal surface and the horizontal surface a minimum of 110 mm out from the base of the vertical surface.
- 2 Cut a strip of Reinforcing Fabric to the required length.

- 3 Apply a base coat of Sealoflex Endura Waterproof Coating to the vertical and horizontal areas.
- 4 Place the Reinforcing Fabric at least 150 mm up from the horizontal surface on the vertical and press into the angle at the base.
- 5 Using a roller or a brush embed the fabric into the base coat making sure there are no creases in the fabric and that no air is trapped beneath it.
- 6 Apply the top coat of Sealoflex Endura Waterproofing Coating to the saturated Reinforcing Fabric.
- 7 Remove the tape before the System cures.

PIPE PENETRATIONS

All pipe penetrations are double reinforced using two pieces of Sealoflex Endura Reinforcing Fabric.

The first piece of fabric should be cut to a width that extends a minimum of 150 mm up the vertical surface of the pipe from the horizontal surface and a minimum of 50 mm from the base of the pipe onto the horizontal surface.

- 1 Cut a length of Reinforcing Fabric 50 mm more than the circumference of the pipe, allowing for the overlap.
- 2 Measure and draw a line 50 mm from the edge of the fabric.
- 3 Make cuts every 20–30 mm from the edge of the fabric up to the line.
- 4 Tape the circumference of the pipe at least 160 mm from the horizontal surface; and tape a square at least 10 mm beyond the length of the fabric strips.
- 5 Apply a base coat of Sealoflex Endura Waterproof Coating to the vertical and horizontal areas.
- 6 Place the solid section of Reinforcing Fabric (which will be at least 150 mm wide) into the base coat on the surface of the pipe and the 'finger cuts' of Reinforcing Fabric into the base coat of the horizontal surface around the pipe as shown.
- 7 Make sure the fabric is 'tight' at the vertical and horizontal junction and that there is a layer of liquid between the fabric overlap.
- 8 Using a roller or a brush embed the fabric into the base coat making sure there are no creases in the fabric and that no air is trapped beneath it.

The second piece of fabric should be cut to a square with sides equal in length to the diameter of the pipe + the length of the 'finger cuts' + 10 mm. (Alternatively, two pieces of fabric should be cut so that they go around the pipe with an overlap of 50 mm.

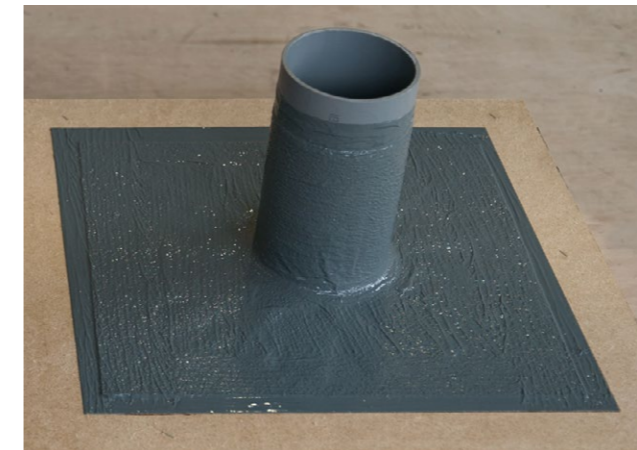

If using one piece of fabric:

- 1 Place the fabric over the centre of the pipe and draw a circle around the circumference.
- 2 Cut out this circle.
- 3 Apply a coat of Sealoflex Endura Waterproofing Coating onto the saturated Reinforcing Fabric on the horizontal surface.
- 4 Place the fabric over the pipe and press down onto the horizontal surface.
- 5 Using a roller or a brush embed the fabric into the coating making sure there are no creases in the fabric and that no air is trapped beneath it.
- 6 Apply the top coat of Sealoflex Endura Waterproof Coating to the saturated fabric around the whole detail area.
- 7 Remove the tape before the System cures.

Fabric Cuts for Pipe Penetration

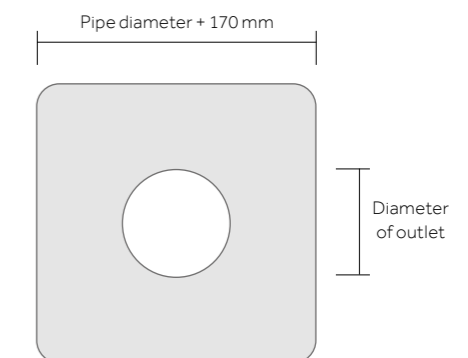
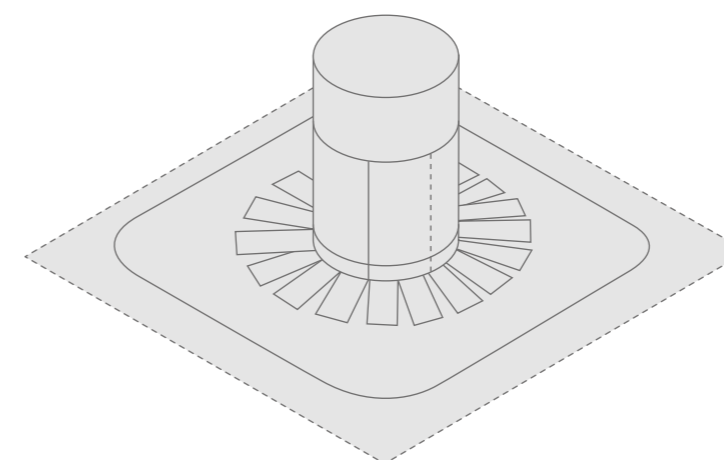
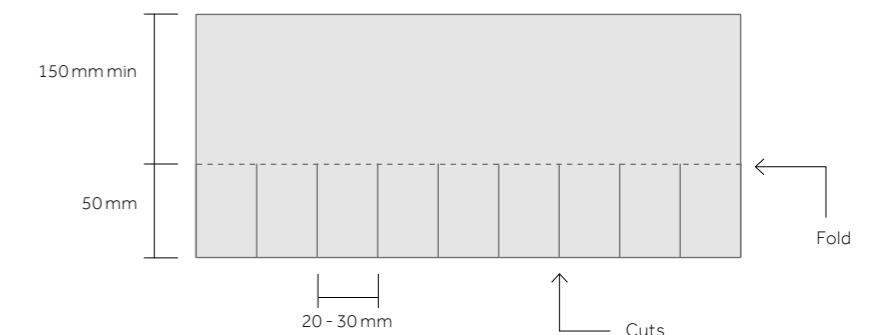
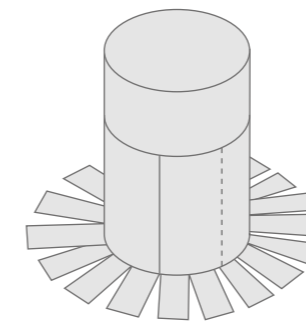

INTERNAL RAINWATER OUTLETS

Before applying the Sealoflex Endura System to an existing internal rainwater outlet, remove any leaf grates or covers and set aside. Clear any debris or blockages from the outlet. Any damage to the outlet should be suitably repaired.

When applying the Endura System to an outlet ensure that drainage will not be impaired.

All internal rainwater outlets are double reinforced using two pieces of Sealoflex Endura Reinforcing Fabric.

The first piece of fabric should be cut to a minimum width of 100 mm so that it extends a minimum of 50 mm into the outlet and a minimum of 50 mm from the top of the outlet onto the horizontal surface.

- 1 Cut a length of Reinforcing Fabric 50 mm more than the circumference of the pipe, allowing for the overlap.
- 2 Measure and draw a line 50 mm from the edge of the fabric.
- 3 Make cuts every 20–30 mm from the edge of the fabric up to the line.
- 4 Tape a square around the outlet at least 10 mm beyond the length of the 'finger cuts'
- 5 Apply a base coat of Sealoflex Endura Waterproof Coating around the outlet and at least 60 mm down the inside surface of the outlet
- 6 Place the solid section of Reinforcing Fabric (which will be at least 50 mm wide) into the base coat on the inside surface of the outlet and the 'finger cuts' of Reinforcing Fabric into the base coat around the outlet as shown.
- 7 Make sure the fabric is 'tight' at the vertical and horizontal junction and that there is a layer of liquid between the fabric overlap.
- 8 Using a roller or a brush embed the fabric into the base coat making sure there are no creases in the fabric and that no air is trapped beneath it.

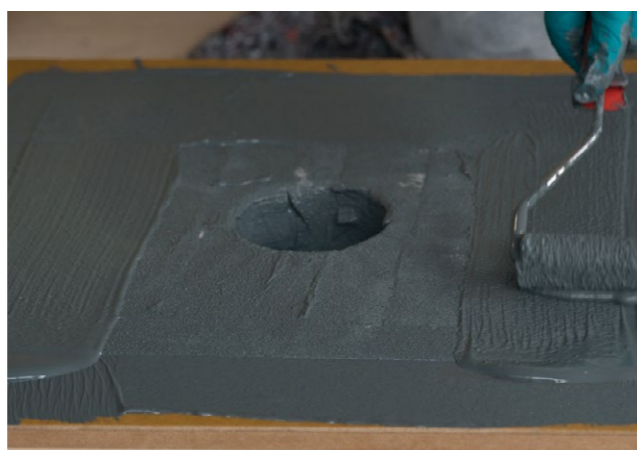
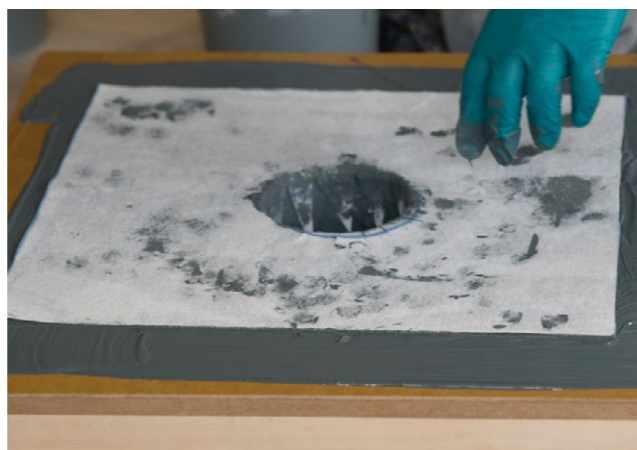
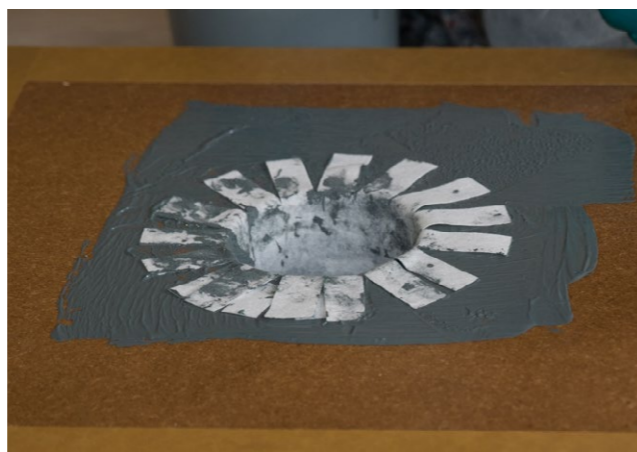

The second piece of fabric should be cut to a square with sides equal in length to the diameter of the outlet + the length of the 'finger cuts' + 10 mm.

- 1 Place the fabric over the centre of the outlet and draw a circle around the circumference.
- 2 Fold the fabric circle in half and make a series of 'star cuts' from the centre of the diameter to the marked line as shown.
- 3 Apply a coat of Sealoflex Endura Waterproofing Coating onto the saturated Reinforcing Fabric on the inside surface of the outlet and around the outlet over the saturated 'finger cuts'.
- 4 Place the fabric over the outlet and press the 'star cuts' down onto the saturate fabric on the inside surface of the outlet.
- 5 Using a roller or a brush embed the fabric into the coating making sure there are no creases in the fabric and that no air is trapped beneath it.

- 6 Apply the top coat of Sealoflex Endura Waterproof Coating to the saturated fabric around the whole detail area.
- 7 Remove the tape before the System cures.
- 8 Once the System fully cures reinstate any leaf grates or covers.

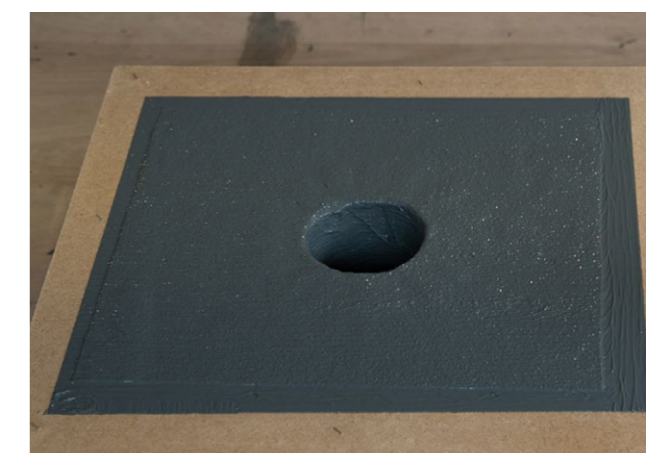

Fabric Cuts for Outlet

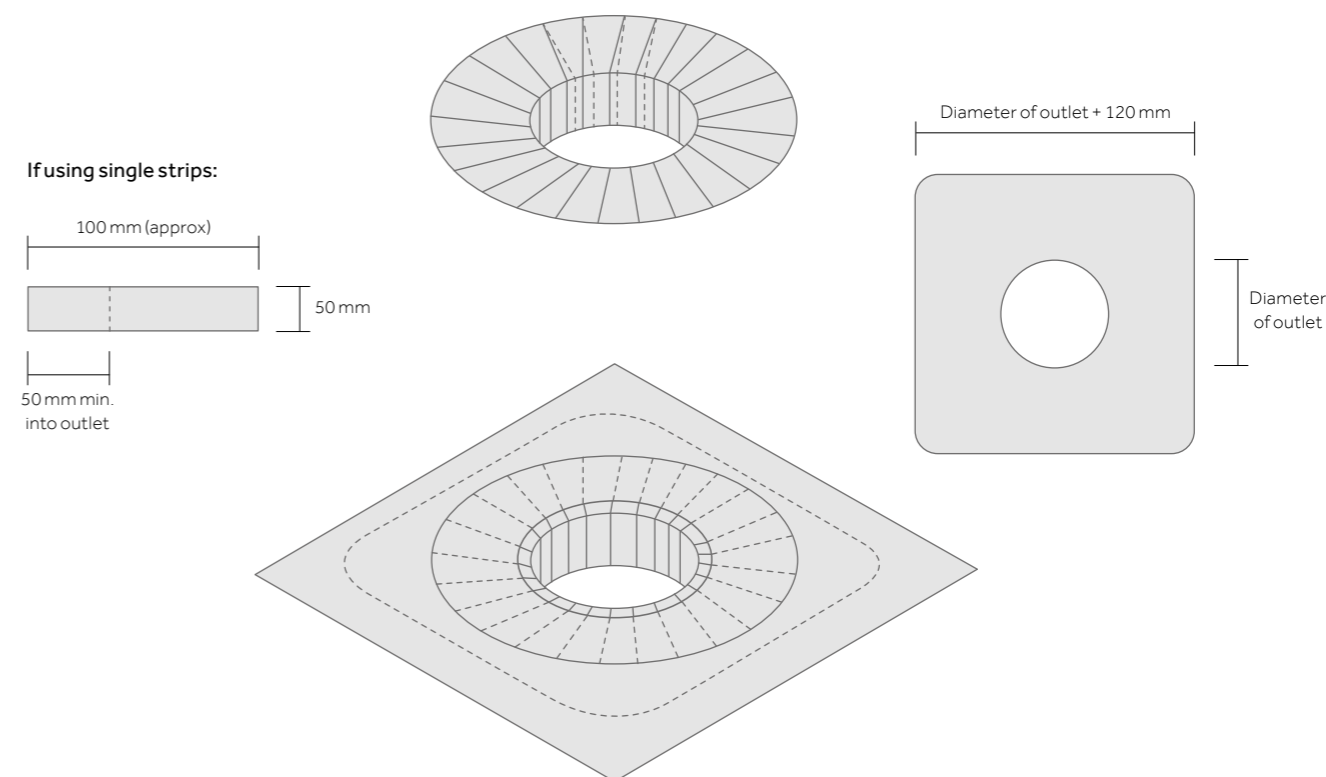

ROOF LIGHTS

All roof light corners must be double reinforced with Sealoflex Endura Reinforcing Fabric.

- 1 Tape around the roof light upstand at least 160 mm from the roof light base and tape around the whole roof light at least 120 mm from the roof light edge.
- 2 Cut circles approximately 150 mm in diameter from the Reinforcing Fabric.
- 3 Fold twice and cut along one fold into the centre.
- 4 Apply a base coat of Sealoflex Endura Waterproof Coating to the area around each corner and place the circles into the base coat as shown.
- 5 Using a roller or a brush embed the pieces of fabric into the base coat making sure there are no creases in the fabric and that no air is trapped beneath them.
- 6 Cut two pieces of Reinforcing Fabric so that they extend 50 mm around each corner as shown.
- 7 Apply a base coat of Sealoflex Endura Waterproof Coating to the vertical and horizontal areas around the front side of the roof light and around each corner, covering the saturated Reinforcing Fabric circles already installed.
- 8 Make cuts 100 mm long that are 50 mm from the edge of the fabric as shown.
- 9 Place the Reinforcing Fabric 10 mm below the tape on the front side of the roof light upstand, press into the angle at the base and 'return' the fabric around each corner as shown.
- 10 Using a roller or a brush embed the fabric into the base coat making sure there are no creases in the fabric and that no air is trapped beneath it.
- 11 Repeat the process on the back side of the roof light.
- 12 Cut two more pieces of Reinforcing Fabric the exact length of the roof light upstand on either side.
- 13 Apply a base coat of Sealoflex Endura Waterproof Coating to the vertical and horizontal areas around one side of the roof light, covering the saturated Reinforcing Fabric already installed.

- 14 Place the Reinforcing Fabric 10 mm below the tape on the roof light upstand, press into the angle at the base and onto the roof deck.
- 15 Using a roller or a brush embed the fabric into the base coat making sure there are no creases in the fabric and that no air is trapped beneath it.
- 16 Apply the top coat of Sealoflex Endura Waterproofing Coating to the saturated Reinforcing Fabric.
- 17 Repeat the process on the other side of the roof light.
- 18 Remove the tape before the System cures.

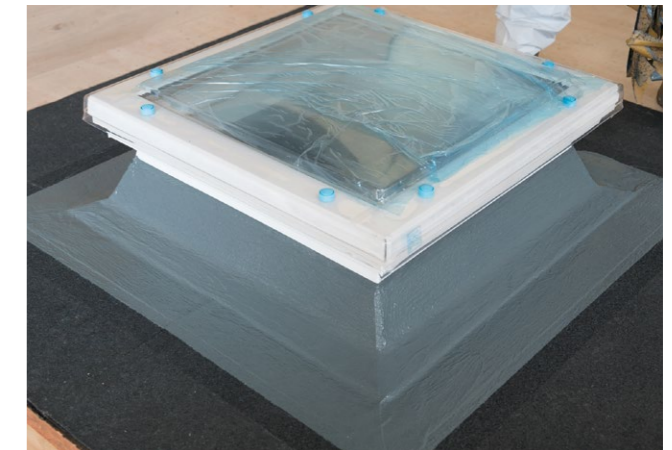

Please Note

- On roof lights with bevelled bases it is necessary to make two cuts at the ends of the front and back pieces of Reinforcing Fabric to accommodate the upstand angles as shown

- When measuring the side pieces of Reinforcing Fabric their length should be that of the roof light base. Once placed into the base coat of the Sealoflex Endura Waterproof Coating, these pieces can be cut along a line from the corner's base edge to the corner's upstand edge as shown.

Fabric Cuts for Roof Light

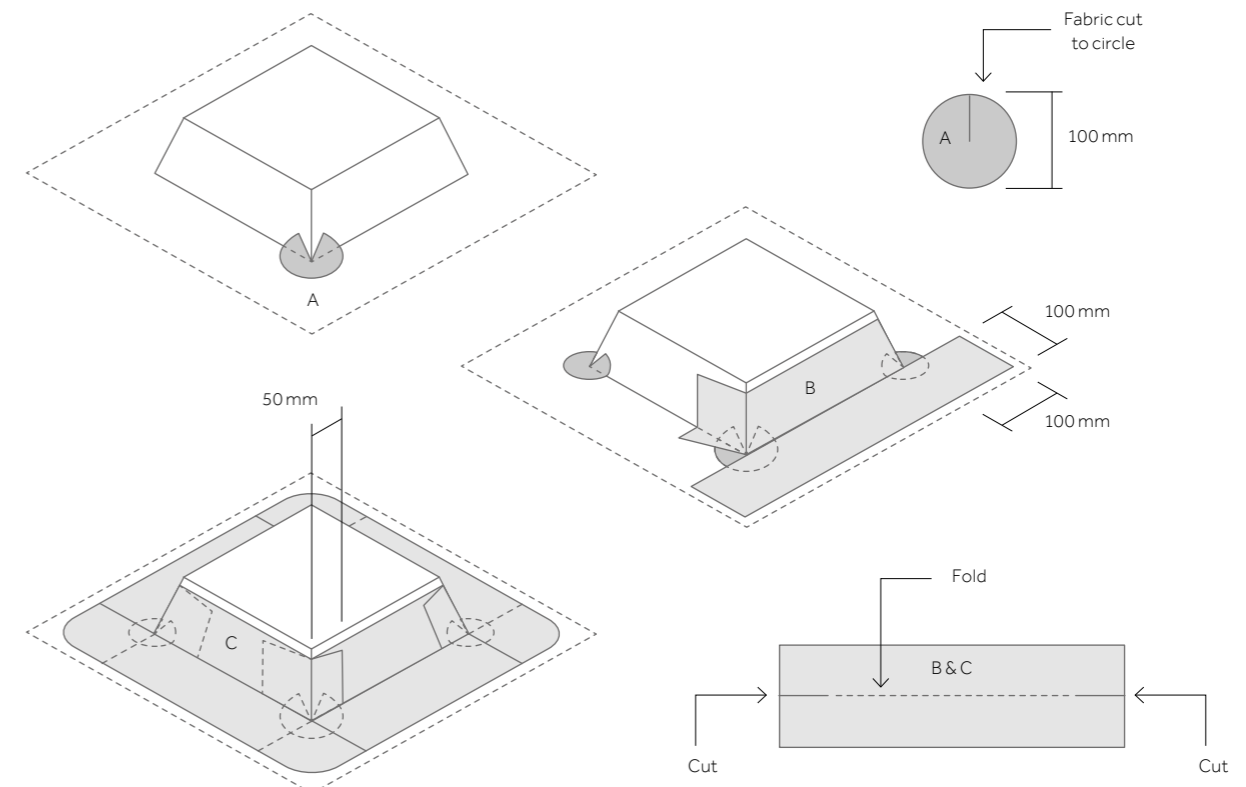

COVER FLASHINGS

Existing Flashings

Depending on the condition of existing lead flashings, these should be lifted to expose the upstand surface beneath.

The Sealoflex Endura System is installed to the upstand detail.

Ensure that the System has completely cured before reinstating the upturned cover flashings.

New Flashings

Pre-cut 25 mm deep chases in all upstands before applying the Sealoflex Endura System.

Chases must be a minimum of 150 mm above the surface of the roof.

If an existing damp proof course (DPC) exists which is less than 150 mm above the surface of the roof, it is advised that a new DPC be installed to the required height.

The Sealoflex Endura System is installed to the upstand detail and must finish flush with the bottom edge of the chase.

Install a lead or lead replacement cover flashing into the chases.

Cut, joint and dress the new flashing as per the manufacturer's instructions.

FIELD AREA

Apply 'wet-on-wet' allowing full membrane application in a single process.

- 1 Set the roll of Sealoflex Endura Reinforcing Fabric at the beginning of the flat area taking care to align it properly.
- 2 Apply a base coat of Sealoflex Endura Waterproof Coating to the area in front of the roll.
- 3 Pull the roll towards you over the base coat.
- 4 Using a roller, embed the fabric into the base coat making sure there are no creases in the fabric and that no air is trapped beneath it.
- 5 Apply a top coat of Sealoflex Endura Waterproofing Coating to the saturated Reinforcing Fabric ensuring even coverage.
- 6 Apply a base coat to the area in front of the roll.
- 7 Pull the roll towards you and repeat the process above.
- 8 When you reach the end of the flat area carefully cut the Reinforcing Fabric in a straight line and make sure the fabric is fully saturated with base coat and top coat.
- 9 Set the roll of fabric adjacent to the installed area with a minimum overlap of 50 mm taking care to align it properly.
- 10 Apply a base coat of Sealoflex Endura Waterproof Coating to the area in front of the roll.
- 11 Pull the roll of fabric towards you over the base coat.
- 12 Using a roller, embed the fabric into the base coat making sure there are no creases in the fabric and that no air is trapped beneath it.
- 13 Apply a top coat of Sealoflex Endura Waterproofing Coating to the saturated Reinforcing Fabric and 'feather in' the overlap.
- 14 Apply a base coat to the area in front of the roll.
- 15 Pull the roll towards you and repeat the process above.
- 16 When the whole area is completed, leave the System to cure.



BMI Group UK Ltd.

BMI House
2 Pitfield
Kiln Farm
Milton Keynes
MK11 3LW
+44 (0) 1908 015760

bmigroup.com/uk

BMI UK & Ireland is part of the world's largest roofing and waterproofing manufacturer. A global business specialising in building materials for today's and tomorrow's needs. BMI is a new name, backed-up with over 180 years of experience and knowledge. Bringing together the roofing expertise of industry leading Icopal and Redland and their experience in the specification, manufacture and supply of flat and pitched roofing solutions. United to deliver excellence for our customers.

Learn more at www.bmigroup.com/uk

Reference code: ICO_IG_2404_1SEALOFLEXENDURAGIG